

AUTOLOAD

AEL-15 ELECTRIC LOADER

- LIGHT WEIGHT
- CAST ALUMINUM CONSTRUCTION
- AVAILABLE IN 110 OR 220 VAC
- SIMPLE AUTOMATIC OPERATION
- SOLID-STATE CONTROLS
- COMPLETELY SELF-CONTAINED
- UP TO 150 LB./HR. CONVEY RATE
- VIRTUALLY MAINTENANCE FREE

AUTOLOAD's AEL-15 Loader is designed to load at 150 lb./hour (@ 35 lbs./cu. ft.). The AEL-15 has quality features usually found only in more expensive vacuum loaders.

The AEL-15 is small, light, completely self-contained, and it costs pennies to operate. The unit is designed to convey virgin plastic pellets. The unique air filter promises years of dependable service, and usually needs cleaning only when changing materials. A simple one-handed push and twist of the sound dampening motor shroud exposes the AEL-15's powerful motor/blower, allowing quick and easy access for maintenance or replacement.

The unit is designed to provide several short bursts of compressed air automatically at the end of each loading cycle, thereby cleaning the filter before the next loading cycle. **(Approximately 1 CFM of CLEAN compressed air @ 100 psi. is required).**

Controls are solid-state simple and operator friendly. The On/Off rocker switch enables a preset program for load-dump-dwell time intervals, and AUTOLOAD's special flapper-mounted level switch keys the loader's automatic operation.

Truly a portable machine, the AEL-15 comes complete with a 12 ft. power cord, 10 ft. of flexible vinyl hose, adjustable suction lance, and even a set of spare motor brushes. Mounting of the unit is easy; a cutout of 4" x 5-1/2" in your machine hopper cover is all that is needed. And the flapper assembly projects only 4" into your hopper, so usable hopper capacity is optimized.

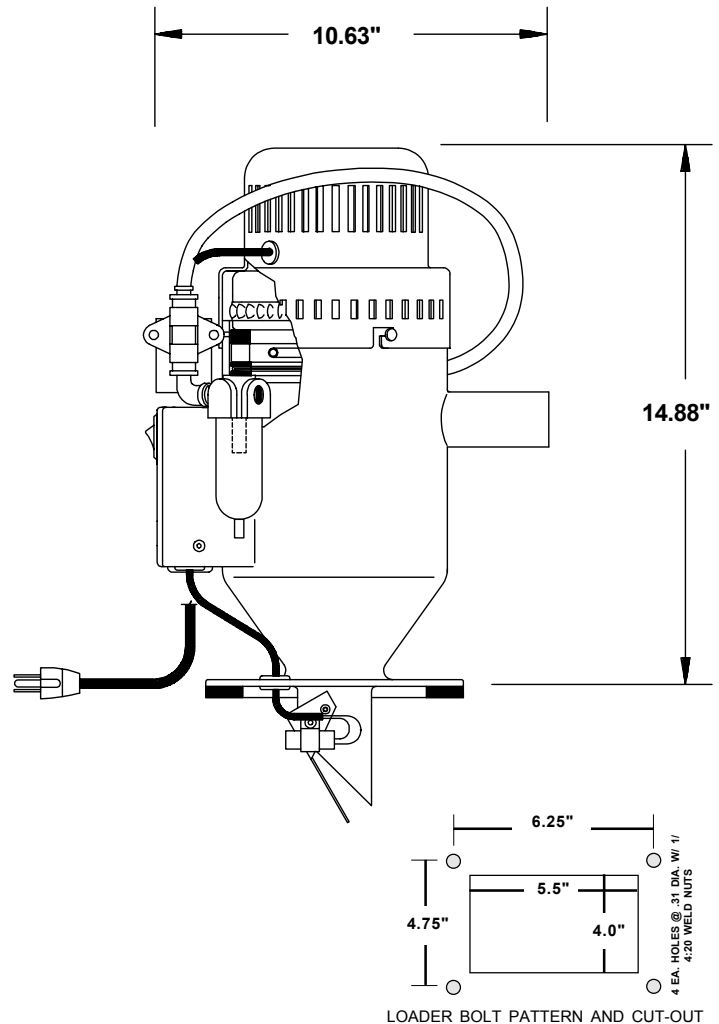

SPECIFICATIONS	
Conveying Capacity:	150 lb./hr. (10 ft. lift)
Chamber Capacity:	3 lb. @ 35 lb./cu. ft.
Power Required	6.0 amps @ 110/1/60 3.0 amps @ 220/1/60
Blower Speed:	1800 RPM
Air Flow:	93 SCFM
Line Size:	1.5 inch ID
Chamber Assembly Wt.:	8.5 lb.
Shipping Weight (complete):	16 lb. (45" x 16" x 7")

AUTOLOAD | Phone 1-800-428-8653 — Fax 1-703-490-7063

TB: AL0510 - R0 9/24/02

[PRICES AND SPECIFICATIONS MAY CHANGE WITHOUT NOTICE - ALL SALES ARE SUBJECT TO STANDARD CONDITIONS OF SALE]